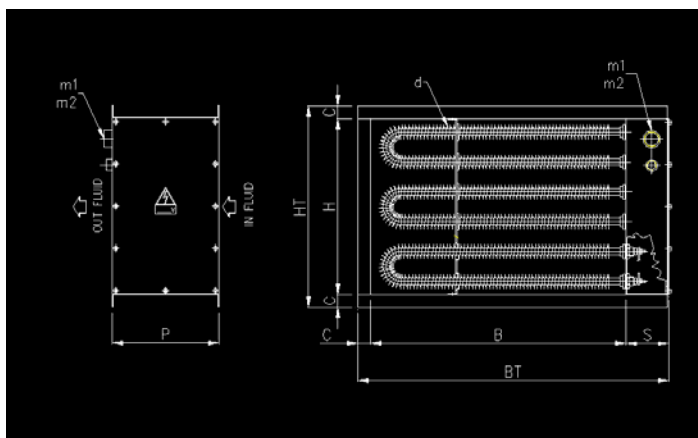

Figure 1: Typical sketch of a "Through Duct Heater"



### GENERAL CHARACTERISTICS

The electric duct heaters have been developed to satisfy the need of temperature controlled air or gas flows which is present in several industrial processes. They are designed to be inserted into ventilation ducts, tubes, ovens or autoclaves and are directly flown by the process air or gas.

The heating elements are finned to increase the heat exchange. However, if the heated fluid contains particles which could clog the fins, the duct heater is manufactured using smooth heating elements.

These products are designed by our technical department on the basis of customer provided functional requirements. Design is supported by purpose-developed software that allow to define the design parameters and to verify the corresponding thermodynamic performances. The analysis yields a precise picture of the heater operating conditions. The iteration between design and analysis leads to define:

1. the specific power
2. the resulting **pressure drops**
3. the **maximum sheath temperature** and, consequently, the safety devices to be used
4. the materials to be used in the construction
5. The duct heater main dimensions
6. the thermodynamic behaviour of the duct heater in the different operational conditions that are foreseen

The manufacturing experience built up in several years of operation in the market, coping with the most different applications, enables us to suggest to our customers materials and technical solutions which are best suited to the application of interest. The results of the thermodynamic calculations, performed to prove the capability of the duct heater to operate as requested, are provided already as part of the offer.

The air duct heaters can be of two types:

- "Through Duct heaters" (that become an integral part of the for ventilation duct system)
- "Plug-in Duct heaters" (which are coupled with a flange to the plant)

A typical sketch of a "Through Duct Heater" is shown in Figure 1, the one of a "plug-in" heater is shown in Figure 2. In both cases the heating elements are mounted using threaded bushings which make maintenance operations easy.

### TECHNICAL DATA

(see also Figure 1 and Figure 2)

<b>B x H</b>	Flow channel dimensions
<b>BT</b>	Overall width
<b>HT</b>	Overall height
<b>PT</b>	Flange overall envelope
<b>P</b>	Contact box depth
<b>S</b>	Contact box height
<b>C</b>	Frame width
<b>d</b>	Supporting Baffle
<b>M1</b>	Female sleeve for power cable glands
<b>M2</b>	Female sleeve for signal cable glands

Figure 2: Typical sketch of a "Plug-In Duct Heater"

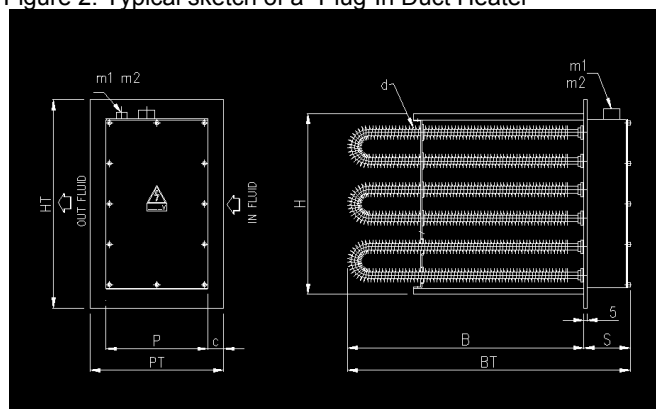

**HIGH TEMPERATURE DESIGN CONCEPT**

In some cases, the high operating temperature impose a construction which foresees a “distancing” of the electric contact box (“cold head” construction). In these cases each element is fixed both to the plant coupling surface and to the contact box structure using a threaded bushing complete with seal and nut (see Figure 3)

If the operating temperature is too high (i.e. > 300 °C) to guarantee tightness by means of seals, the “cold head” construction can be realised introducing distancing tubes, TIG-welded to both surfaces (see Figure 4). This solution is also used when the maximum tightness has to be insured (see, for instance, the case of explosion-proof duct heaters) but does not allow to dismount the heating elements. In all cases the thermal expansion needs of the heating elements are adequately supported.

Figure 3: typical cold head heaters construction scheme

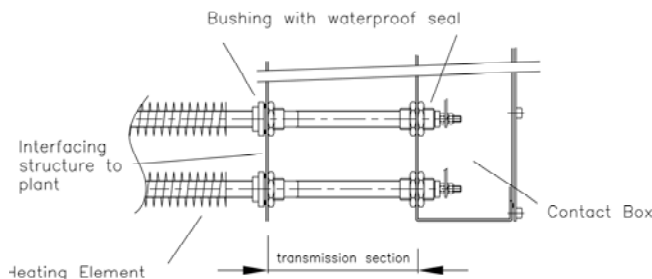
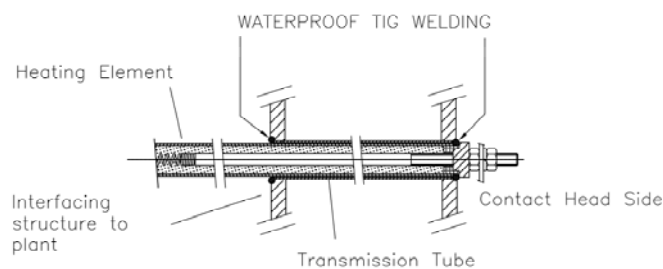

Figure 3: welded cold head heaters construction scheme



**THERMAL SAFETY DEVICE**

Each heater is provided with a safety device that limits the sheath temperature in case of unforeseen events. This device protects at the same time the heater and the plant the heater belongs to. The type of safety device to be used is defined by our Technical Department depending on the process needs.

**TYPICAL INDUSTRIAL APPLICATIONS**

- ↻ Air Conditioning
- ↻ Pre-heating of ovens
- ↻ Heating in autoclaves

**SPECIAL CONSTRUCTIONS**

The electric duct heaters are a very flexible product which can be used in the most different applications. The following are worth being mentioned :

- heating of gases in a potentially explosive atmosphere (ATEX duct heaters for fluids circulating in non classified areas)
- drying in silos by means of high power installations
- heating in railways carriages
- construction of engine mechanical overload absorption benches with incorporated ventilators.

An example of an explosion-proof duct heater is shown in the photograph below.



An example of a high power duct heater for drying in silos is shown in the photograph below.



If requested, the air conveyors required to connect the duct heater inlet and outlet sections to the ducting system can be provided too.

**DATA REQUIRED FOR A CORRECT DEFINITION OF AN ELECTRIC DUCT HEATER**

To design an electric duct heater a set of data is required. The availability of all the data is a pre-requisite for an optimum sizing and for a precise definition of the heating power. Table 1 hereunder summarises the required data.

Table 1: data required to design an electric duct heater

Design Data	Notes	
<b>Thermodynamic Data</b>		
<b>Fluid</b>	⇒ If the fluid is not air and is not a common gas, please specify the thermodynamic characteristics at, at least, three different temperatures  ⇒ More information on fluids characteristics are contained in the <b>“Useful Technical Information”</b> Volume	
<b>Fluid flow rate</b>	⇒ If variable please specify min. and max value in m <sup>3</sup> /h	
Maximum allowable pressure drop	⇒ in mm H <sub>2</sub> O	
<b>Design Temperature</b>	⇒ in degrees centigrade	
<b>Inlet Temperature</b>	⇒ in degrees centigrade	
<b>Outlet Temperature</b>	⇒ in degrees centigrade	
<b>Type of duct heater</b>	⇒ through duct heater / plug-in duct heater	
<b>Type of heating elements</b>	⇒ smooth (for fluids with dust or suspended particles) or finned (in all other cases)	
<b>Duct or Flange Dimensions</b>	⇒ please specify duct or coupling flange dimensions as well as maximum allowable envelope	
Masses to be heated	⇒ Please specify the most significant plant masses (weight and materials) that are heated by the flowing fluid	
<b>Electrical Data</b>		
Installed Power	⇒ in kW	
<b>Power Supply Voltage</b>	⇒ in Volt	
<b>Type of Electrical connection</b>	⇒ Star / Delta / Monophase	
Number of stages	⇒	
<b>Contact Head Protection</b>	⇒ IP 55/65	
<b>Control</b>		
Power	⇒ On/Off ⇒ SCR (Solid Control Relais) ⇒ On/Off + SCR	
Fluid thermal sensor	⇒ please specify number and type	
Sheath thermal sensor	⇒ please specify number and type	
<b>Accessories</b>		
Thermal Insulation	Masterwatt Standard as a function of the operating temperature	
Cable glands	Please specify: material and Ø external of the power supply cable	
<b>ATEX Certification</b>		
Equipment installed in potentially explosive areas	⇒ ATEX	
	Dangerous area classification	
	Zone	
	Maximum allowable temperature class (e.g. T3)	
	Ambient Temperature (e.g. -10°C + 40 °C)	
More information inside the Explosion Proof Heater catalogue.		

NOTE: Data in bold character must be provided to insure a correct sizing of the heater. For the remaining data, missing specific customer information, Masterwatt standards will be applied

### CATALOGUE STANDARD DUCT HEATERS

Many applications do not present complex heating needs but, on the other hand, require to limit the duct heater lead time and cost as well as to insure the constant availability on stock of exchange heating elements.

MAXIMA duct heaters have been conceived just to respond to these needs: they are through duct heaters, suitable to heat air in the velocity range 2.5 to 5 m/s and to offer a wide range of heating powers (from 2.5 to 315 kW).

These duct heaters can allow to obtain air temperature increases up to 40 °C and can work with operating temperatures as high as 100 °C.

The contact box degree of protection is IP55.

### TECHNICAL DATA

(see also Figure 5)

Base	= B (see catalogue)
Height	= H (see catalogue)
Depth	= P (see catalogue)
Frame Height	= c = 30 mm
Contact Head Height	= S = 100 mm
Maximum Height	= H + 2 x c
Maximum Width	= B + S + c
Power supply sleeve	= m1 size 1" (1 per stage)
Signal sleeve	= m2 size 1/2" (1 per sensor)
Supporting Baffle	= d (only for series 525÷1025)

### POWER SUPPLY

Power supply shall be 400 V tri-phase, star connection (delta connection is not possible). Given the air flow section and air flow rate, three different types of duct heaters can be supplied, with, respectively, 1, 2 or 3 power supply stages. In this way it is possible to optimise the number of heating steps and the corresponding heating power.

As an example, looking at duct heaters series 300 (see Table 2) the following combinations are possible (see also Table 3 and Figure 6):

Table 3: possible power supply combinations of MAXIMA duct heaters series 300

Module	Power Supply 1 stage		Power Supply 2 stages		Power Supply 3 stages	
	N°	kW	N°	kW	N°	kW
<b>A1</b>	<b>1</b>	<b>2.4</b>	---	---	---	---
<b>A2</b>	<b>1</b>	<b>4.8</b>	<b>2</b>	<b>2.4+2.4</b>	---	---
<b>A3</b>	<b>1</b>	<b>7.2</b>	<b>2</b>	<b>4.8+2.4</b>	<b>3</b>	<b>2.4x3</b>

Figure 5: typical scheme of a MAXIMA duct heater

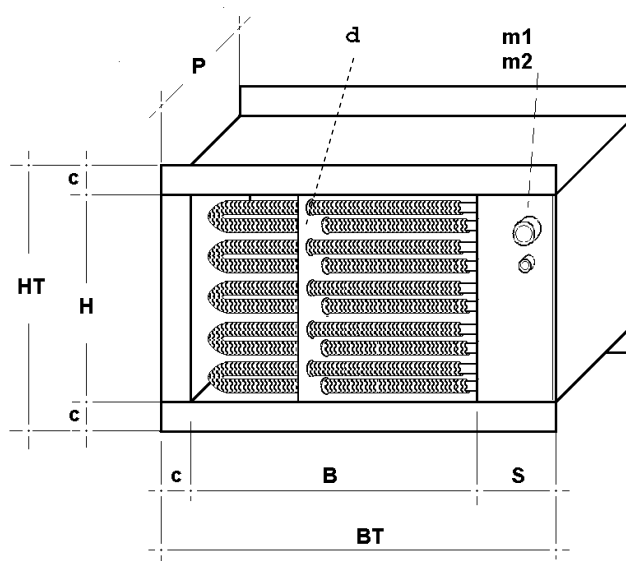
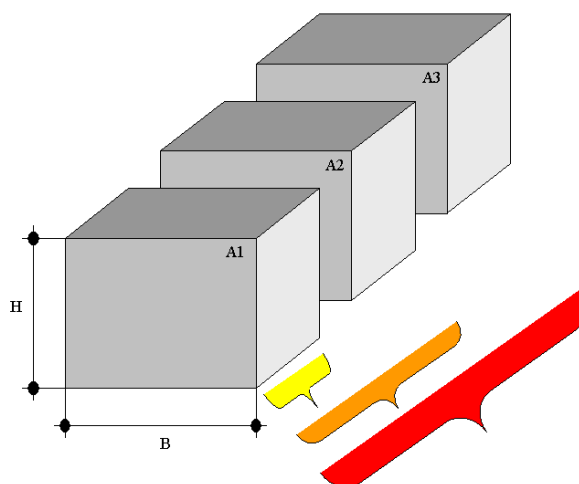

Figure 6: possible power supply combinations of a MAXIMA duct heater



### SAFETY SENSORS

MAXIMA duct heaters can be equipped, if requested, with a safety sensor which intervenes when the elements skin temperature exceeds the nominal values. The following alternatives are possible:

- adjustable capillary thermostat, liquid dilatation sensing element, 50 ÷ 300 °C (automatic reset)
- adjustable capillary thermostat, liquid dilatation sensing element, 50 ÷ 300 °C (manual reset)
- J-type thermocouple (see also Masterwatt catalogue "Thermocouples and Thermoresistances")
- PT100 thermoresistance (see Masterwatt catalogue "Thermocouples and Thermoresistances").

The maximum number of safety sensors that can be installed is equal to the maximum number of power supply stages of each model. A duct heater Module B2, for instance, can accommodate up to 2 sensors.

**HOW TO SELECT A MAXIMA DUCT HEATER**

MAXIMA duct heaters can be selected from the list shown in Table 2. To identify the one that best suits your needs, you must know the following data:

- Air flow rate Q (or air velocity V)
- Required temperature increase ( $\Delta T$ )
- Ventilation duct section

The selection procedure is the following:

1. identify, amongst the proposed duct heaters, those having a duct section (B x H – see Figure 5) quite similar to the desired one (dimensions difference not exceeding 25 %). When choosing, please have in mind that, in case your duct has a section that is small than the one of the heater, the connection air conveyor shall have an inclination not exceeding 20° (see Figure 6).

Figure 6: prescriptions for the air conveyors connecting the ventilation ducts to the heater

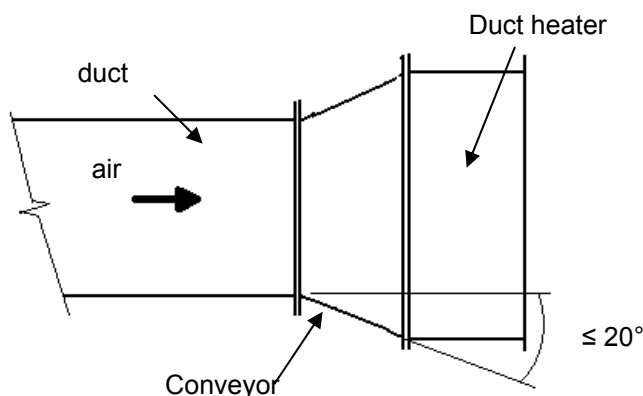

2. Select, amongst the heaters identified in previous step, those having a minimum flow rate (see column  $Q_{min}$ ) which is as near as possible (error  $\leq \pm 25\%$ ) to the operational flow rate. If you do not know the plant flow rate but only the air velocity, the air flow rate flowing through the duct heaters can be calculated using the following formula:

$$Q = V \times B \times H \times 3600$$

where:

V = air velocity (in m/s)

B, H = duct dimensions (in m)

Q = air flow rate through the duct heater (in  $m^3/h$ )

3. Select, amongst the heaters identified in previous step, the one in which the temperature increase (see column  $dt^\circ$ ) is as near as possible (error  $\leq \pm 7^\circ C$ ) to the desired temperature increase  $\Delta T$

4. Verify the temperature increase that is available in the case of interest employing the following formula:

$$dt^\circ_{effective} = \frac{Coeff\_T^\circ}{Q}$$

where:

Coef<sub>T</sub><sup>°</sup> = heater specific coefficient (see corresponding column in the catalogue)

Q = air flow rate through the heater

$dt^\circ_{effective}$  = effective temperature increase obtained with the selected duct heater in the assigned operational conditions

At this point, if the effective temperature increase is equal to the desired value (or exceeds it by no more than 6 or 7 °C) the best suited duct heaters has been identified.

If, on the contrary, the effective temperature increase is lower than the desired one, it will be necessary to select, amongst the heaters identified in point 2, another duct heater characterised by a temperature increase (see column  $dt^\circ$ ) that is higher. After that, the verification described in point 4 shall be repeated.

If, finally, the effective temperature increase is much higher than the desired one (8 °C or more of difference), it will be necessary to select, amongst the heaters identified in point 2, another duct heater characterised by a temperature increase (see column  $dt^\circ$ ) that is lower. After that, the verification described in point 4 shall be repeated.

**Example of MAXIMA duct heater selection**

Design data:

**Flow Rate:** 2000  $m^3/h$

**Duct section:** 500 x 500 mm

**Required temperature increase ( $\Delta T$ ):** 20 °C

Heaters having a compatible section B x H

- ☞ Series 450 – Module B1, B2, B3 (section 450 x 460)
- ☞ Series 525 – Module B1, B2, B3 (section 525 x 460)
- ☞ Series 625 – Module B1, B2, B3 (section 625 x 460)

Heaters having a compatible minimum flow rate

- ☞ Series 450 – Module B1, B2, B3 ( $Q_{min} = 1863 m^3/h$ )
- ☞ Series 525 – Module B1, B2, B3 ( $Q_{min} = 2173 m^3/h$ )

Heaters best suiting the desired  $\Delta T$ 

- ☞ Series 450 – Module B2 ( $dt^\circ = 24,51^\circ C$ )
- ☞ Series 525 – Module B2 ( $dt^\circ = 24,24^\circ C$ )

 $dt^\circ_{effective}$  verification

- ☞ 450 – B2 (Coef<sub>T</sub><sup>°</sup> = 45696  $dt^\circ_{effective} = 22,8^\circ C$ )
- ☞ 525 – B2 (Coef<sub>T</sub><sup>°</sup> = 52726  $dt^\circ_{effective} = 26,4^\circ C$ )

**SELECTED DUCT HEATER**

⇒ Series 450 – Module B2

Table 2: available MAXIMA duct heaters

Code	Base (B) mm	Height (H) mm	Depth (P) mm	Power kW	Minimum flow rate (Q <sub>min</sub> ) m <sup>3</sup> /h	Temperature increase (dt°) °C	Temperature coefficient (Coeff. T°) °C m <sup>3</sup> /h
<b>Module A</b>							
300 – A1	300	250	150	2.4	675	10.41	7030
300 – A2	300	250	250	4.8	675	20.81	14060
300 – A3	300	250	380	7.2	675	31.22	21090
<b>Module B</b>							
300 – B1	300	460	150	4.8	1242	11.31	14060
300 – B2	300	460	250	9.6	1242	22.62	28120
300 – B3	300	460	380	14.4	1242	33.93	42181
<b>Module C</b>							
300 – C1	300	680	150	7.2	1836	11.48	21090
300 – C2	300	680	250	14.4	1836	22.96	42181
300 – C3	300	680	380	21.6	1836	34.43	63271
<b>Module A</b>							
350 – A1	350	250	150	3.0	788	11.15	8788
350 – A2	350	250	250	6.0	788	22.30	17575
350 – A3	350	250	380	9.0	788	33.45	26363
<b>Module B</b>							
350 – B1	350	460	150	6.0	1449	12.12	17575
350 – B2	350	460	250	12.0	1449	24.24	35151
350 – B3	350	460	380	18.0	1449	36.36	52726
<b>Module C</b>							
350 – C1	350	680	150	9.0	2142	12.30	26363
350 – C2	350	680	250	18.0	2142	24.60	52726
350 – C3	350	680	380	27.0	2142	36.89	79089
<b>Module A</b>							
450 – A1	450	250	150	3.9	1013	11.27	11424
450 – A2	450	250	250	7.8	1013	22.55	22848
450 – A3	450	250	380	11.7	1013	33.82	34272
<b>Module B</b>							
450 – B1	450	460	150	7.8	1863	12.25	22848
450 – B2	450	460	250	15.6	1863	24.51	45696
450 – B3	450	460	380	23.4	1863	36.76	68544
<b>Module C</b>							
450 – C1	450	680	150	11.7	2754	12.43	34272
450 – C2	450	680	250	23.4	2754	24.87	68544
450 – C3	450	680	380	35.1	2754	37.30	102815
<b>Module A</b>							
525 – A1	525	250	150	4.5	1181	11.15	13181
525 – A2	525	250	250	9.0	1181	22.30	26363
525 – A3	525	250	380	13.5	1181	33.45	39544
<b>Module B</b>							
525 – B1	525	460	150	9.0	2174	12.12	26363
525 – B2	525	460	250	18.0	2174	24.24	52726
525 – B3	525	460	380	27.0	2174	36.36	79089
<b>Module C</b>							
525 – C1	525	680	150	13.5	3213	12.30	39544
525 – C2	525	680	250	27.0	3213	24.60	79089
525 – C3	525	680	380	40.5	3213	36.89	118633

Table 2: available MAXIMA duct heaters (continued)

Code	Base (B) mm	Height (H) mm	Depth (P) mm	Power kW	Minimum flow rate (Q <sub>min</sub> ) m <sup>3</sup> /h	Temperature increase (dt°) °C	Temperature coefficient (Coeff. T°) °C m <sup>3</sup> /h
<b>Module A</b>							
625 – A1	625	250	150	5.4	1406	11.24	15818
625 – A2	625	250	250	10.8	1406	22.48	31635
625 – A3	625	250	380	16.2	1406	33.72	47453
<b>Module B</b>							
625 – B1	625	460	150	10.8	2588	12.22	31635
625 – B2	625	460	250	21.6	2588	24.43	63271
625 – B3	625	460	380	32.4	2588	36.65	94906
<b>Module C</b>							
625 – C1	625	680	150	16.2	3825	12.40	47453
625 – C2	625	680	250	32.4	3825	24.79	94906
625 – C3	625	680	380	48.6	3825	37.19	142360
<b>Module A</b>							
700-6 – A1	700	400	150	12.0	2520	13.94	35151
700-6 – A2	700	400	250	24.0	2520	27.87	70301
700-6 – A3	700	400	380	36.0	2520	41.81	105452
<b>Module B</b>							
700-6 – B1	700	775	150	24.0	4883	14.39	70301
700-6 – B2	700	775	250	48.0	4883	28.77	140602
700-6 – B3	700	775	380	72.0	4883	43.16	210903
<b>Module C</b>							
700-6 – C1	700	1150	150	36.0	7245	14.54	105452
700-6 – C2	700	1150	250	72.0	7245	29.09	210903
700-6 – C3	700	1150	380	108.0	7245	43.63	316355
<b>Module A</b>							
700-9 – A1	700	590	150	18.0	3717	14.17	52726
700-9 – A2	700	590	250	36.0	3717	28.35	105452
700-9 – A3	700	590	380	54.0	3717	42.52	158177
<b>Module B</b>							
700-9 – B1	700	1150	150	36.0	7245	14.54	105452
700-9 – B2	700	1150	250	72.0	7245	29.09	210903
700-9 – B3	700	1150	380	108.0	7245	43.63	316355
<b>Module C</b>							
700-9 – C1	700	1705	150	54.0	10742	14.71	158177
700-9 – C2	700	1705	250	108.0	10742	29.43	316355
700-9 – C3	700	1705	380	162.0	10742	44.14	474532
<b>Module A</b>							
850-6 – A1	850	400	150	15.0	3060	14.35	43938
850-6 – A2	850	400	250	30.0	3060	28.69	87876
850-6 – A3	850	400	380	45.0	3060	43.04	131814
<b>Module B</b>							
850-6 – B1	850	775	150	30.0	5929	14.81	87876
850-6 – B2	850	775	250	60.0	5929	29.62	175753
850-6 – B3	850	775	380	90.0	5929	44.43	263629
<b>Module C</b>							
850-6 – C1	850	1150	150	45.0	8798	14.97	131814
850-6 – C2	850	1150	250	90.0	8798	29.94	263629
850-6 – C3	850	1150	380	135.0	8798	44.91	395443

Table 2: available MAXIMA duct heaters (continued)

Code	Base (B) mm	Height (H) mm	Depth (P) mm	Power kW	Minimum flow rate (Q <sub>min</sub> ) m <sup>3</sup> /h	Temperature increase (dt°) °C	Temperature coefficient (Coeff. T°) °C m <sup>3</sup> /h
<b>Module A</b>							
850-9 – A1	850	590	150	22.5	4514	14.59	65907
850-9 – A2	850	590	250	45.0	4514	29.18	131814
850-9 – A3	850	590	380	67.5	4514	43.77	197722
<b>Module B</b>							
850-9 – B1	850	1150	150	45.0	8798	14.97	131814
850-9 – B2	850	1150	250	90.0	8798	29.94	263629
850-9 – B3	850	1150	380	135.0	8798	44.91	395443
<b>Module C</b>							
850-9 – C1	850	1705	150	67.5	13043	15.15	197722
850-9 – C2	850	1705	250	135.0	13043	30.29	395443
850-9 – C3	850	1705	380	202.5	13043	45.44	593165
<b>Module A</b>							
1025-6 – A1	1025	400	150	18.0	3690	14.28	52726
1025-6 – A2	1025	400	250	36.0	3690	28.55	105452
1025-6 – A3	1025	400	380	54.0	3690	42.83	158177
<b>Module B</b>							
1025-6 – B1	1025	775	150	36.0	7149	14.74	105452
1025-6 – B2	1025	775	250	72.0	7149	29.48	210903
1025-6 – B3	1025	775	380	108.0	7149	44.21	316355
<b>Module C</b>							
1025-6 – C1	1025	1150	150	54.0	10609	14.90	158177
1025-6 – C2	1025	1150	250	108.0	10609	29.80	316355
1025-6 – C3	1025	1150	380	162.0	10609	44.69	474532
<b>Module A</b>							
1025-9 – A1	1025	590	150	27.0	5443	14.52	79089
1025-9 – A2	1025	590	250	54.0	5443	29.04	158177
1025-9 – A3	1025	590	380	81.0	5443	43.56	237266
<b>Module B</b>							
1025-9 – B1	1025	1150	150	54.0	10609	14.90	158177
1025-9 – B2	1025	1150	250	108.0	10609	29.80	316355
1025-9 – B3	1025	1150	380	162.0	10609	44.69	474532
<b>Module C</b>							
1025-9 – C1	1025	1705	150	81.0	15729	15.07	237266
1025-9 – C2	1025	1705	250	162.0	15729	30.15	474532
1025-9 – C3	1025	1705	380	243.0	15729	45.22	711798
<b>Module A</b>							
1175 – A1	1175	1900	150	105.0	20093	15.30	307567
1175 – A2	1175	1900	250	210.0	20093	30.59	615134
1175 – A3	1175	1900	380	315.0	20093	45.89	922701